

COURSE : DISASTER MANAGEMENT (MA/ MSc PART I)

Paper : VI

Prepared by : Prof. B. K. Mishra, Course coordinator

Topic : Research Methodology

INTRODUCTION

Before embarking on the details of research methodology and techniques, it seems appropriate to present a brief overview of the research process. Research process consists of series of actions or steps necessary to effectively carry out research and the desired sequencing of these steps. The chart shown in Figure well illustrates a research process. The chart indicates that the research process consists of a number of closely related activities, as shown through I to VII. But such activities overlap continuously rather than following a strictly prescribed sequence.

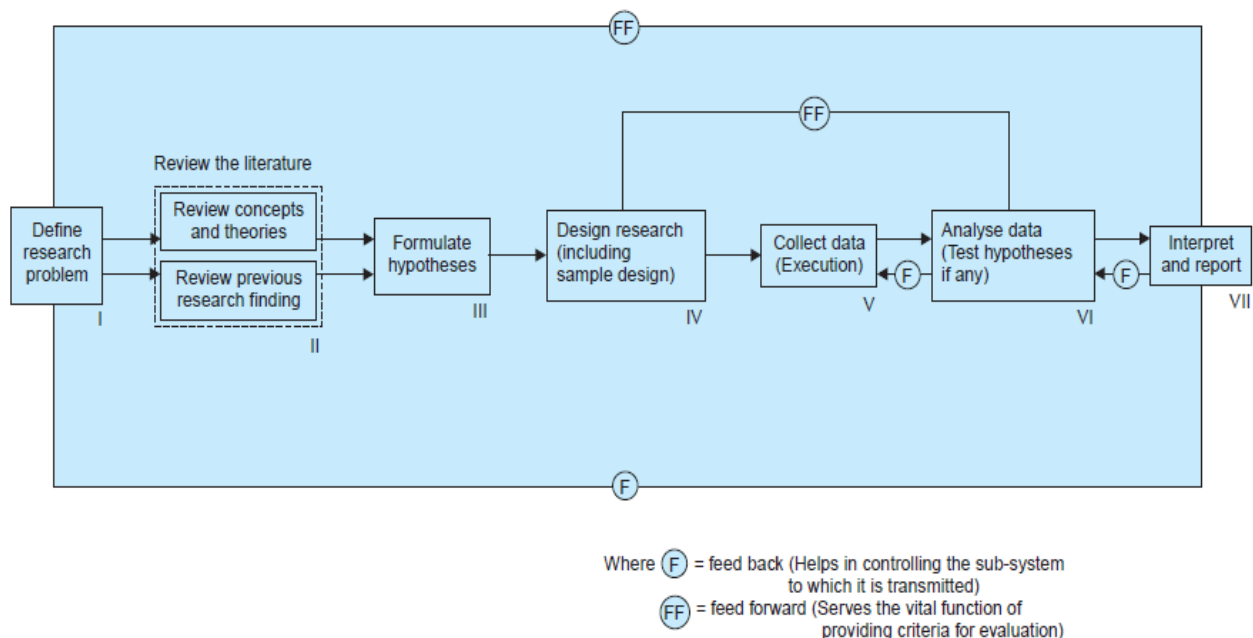

Steps involved in Research Process in Research Methodology

At times, the first step determines the nature of the last step to be undertaken. If subsequent procedures have not been taken into account in the early stages, serious difficulties may arise which may even prevent the completion of the study. One should remember that the various steps involved in a research process are not mutually exclusive; nor they are separate and distinct.

They do not necessarily follow each other in any specific order and the researcher has to be constantly anticipating at each step in the research process the requirements of the subsequent steps. However, the following order concerning various steps provides a useful procedural guideline regarding the research process:

1. formulating the research problem;
2. extensive literature survey;

3. developing the hypothesis;
4. preparing the research design;
5. determining sample design;
6. collecting the data;
7. execution of the project;
8. analysis of data;
9. hypothesis testing;
10. generalizations and interpretation, and
11. preparation of the report or presentation of the results, i.e., formal write-up of conclusions reached.

1. **Formulating the research problem:** There are two types of research problems, those which relate to states of nature and those which relate to relationships between variables. At the very outset the researcher must single out the problem he wants to study, i.e., he must decide the general area of interest or aspect of a subject-matter that he would like to inquire into. Initially the problem may be stated in a broad general way and then the ambiguities, if any, relating to the problem be resolved. Then, the feasibility of a particular solution has to be considered before a working formulation of the problem can be set up. The formulation of a general topic into a specific research problem, thus, constitutes the first step in a scientific enquiry. Essentially two steps are involved in formulating the research problem, viz., understanding the problem thoroughly, and rephrasing the same into meaningful terms from an analytical point of view.
2. **Extensive literature survey:** Once the problem is formulated, a brief summary of it should be written down. It is compulsory for a research worker writing a thesis for a Ph.D. degree to write synopsis of the topic and submit it to the necessary Committee or the Research Board for approval. At this juncture the researcher should undertake extensive literature survey connected with the problem.
3. **Development of working hypotheses:** After extensive literature survey, researcher should state in clear terms the working hypothesis or hypotheses. Working hypothesis is tentative assumption made in order to draw out and test its logical or empirical consequences. As such the manner in which research hypotheses are developed is particularly important since they provide the focal point for research.
4. **Preparing the research design:** The research problem having been formulated in clear cut terms, the researcher will be required to prepare a research design, i.e., he will have to state the conceptual structure within which research would be conducted. The preparation of such a design facilitates research to be as efficient as possible yielding maximal information.
5. **Determining sample design:** The researcher must decide the way of selecting a sample or what is popularly known as the sample design. In other words, a sample design is a definite plan determined before any data are actually collected for obtaining a sample from a given population. Thus, the plan to select 12 of a city's 200 drugstores in a certain way constitutes a sample design. Samples can be either probability samples or non-probability samples.
6. **Collecting the data:** In dealing with any real life problem it is often found that data at hand are inadequate, and hence, it becomes necessary to collect data that are

appropriate. There are several ways of collecting the appropriate data which differ considerably in context of money costs, time and other resources at the disposal of the researcher.

7. Execution of the project: Execution of the project is a very important step in the research process. If the execution of the project proceeds on correct lines, the data to be collected would be adequate and dependable. The researcher should see that the project is executed in a systematic manner and in time. If the survey is to be conducted by means of structured questionnaires, data can be readily machine-processed. In such a situation, questions as well as the possible answers may be coded. If the data are to be collected through interviewers, arrangements should be made for proper selection and training of the interviewers

8. Analysis of data: After the data have been collected, the researcher turns to the task of analyzing them. The analysis of data requires a number of closely related operations such as establishment of categories, the application of these categories to raw data through coding, tabulation and then drawing statistical inferences. The unwieldy data should necessarily be condensed into a few manageable groups and tables for further analysis. Thus, researcher should classify the raw data into some purposeful and usable categories. Coding operation is usually done at this stage through which the categories of data are transformed into symbols that may be tabulated and counted.

9. Hypothesis-testing: After analyzing the data as stated above, the researcher is in a position to test the hypotheses, if any, he had formulated earlier. Do the facts support the hypotheses or they happen to be contrary? This is the usual question which should be answered while testing hypotheses. Various tests, such as Chi square test, t-test, F-test, have been developed by statisticians for the purpose. The hypotheses may be tested through the use of one or more of such tests, depending upon the nature and object of research inquiry. Hypothesis -testing will result in either accepting the hypothesis or in rejecting it. If the researcher had no hypotheses to start with, generalizations established on the basis of data may be stated as hypotheses to be tested by subsequent researches in times to come.

10. Generalizations and interpretation: If a hypothesis is tested and upheld several times, it may be possible for the researcher to arrive at generalization, i.e., to build a theory. As a matter of fact, the real value of research lies in its ability to arrive at certain generalizations. If the researcher had no hypothesis to start with, he might seek to explain his findings on the basis of some theory. It is known as interpretation. The process of interpretation may quite often trigger off new questions which in turn may lead to further researches.

11. Preparation of the report or the thesis: Finally, the researcher has to prepare the report of what has been done by him. Report should be written in a concise and objective style in simple language avoiding vague expressions such as 'it seems,' 'there may be', and the like. Charts and illustrations in the main report should be used only if they present the information more clearly and forcibly.

